

TOWN OF ELMORE, VT

Monthly Select Board Meeting

Meeting Minutes – prepared by G. Schwartz
Status: Approved

Meeting Date: January 09, 2019

Start Time: 6:35 pm **Adjourn:** 9:00pm

Meeting Attendees: See attached sign in sheet

A. Meeting Minutes Approval:

1. The minutes of the December 12, 2018 Select Board Meeting were approved.

B. SPECIAL TOPICS:

1. Dave Bickford, liaison for EMUU Representative

Notes: A public meeting will be held on Monday January 14, 2019 @ 6:00pm at the Peoples Academy Auditorium, regarding the school merger between EMUU and Stowe to form the Lamoille South Unified School District. Dave noted that the ruling requiring this merger is being challenged in the State Superior Court. In the meantime, the school board is planning for both scenarios including budgets. At the current time it is expected that no school closures will occur for 4 years.

2. Brent Hosking to discuss the fire departments desire to purchase a new fire engine in 2019

Notes: The Elmore Fire Department provided information regarding the need for a new fire truck (copies attached). The new truck is expected to cost approximately \$370,000.00. The Select Board reviewed all of the information. It was the decision of the Select Board to reevaluate the need for the new truck in the next fiscal year.

3. Town Report Distribution Process

Notes: In an effort to reduce the cost of mailing the Town report to every household, the Select Board decided that the report would be distributed in the following ways;

- a. Electronic distribution via email
- b. In person via pickup at the Town Offices
- c. Mailed upon request

Sharon Draper to put a notice in the News and Citizen.

TOWN OF ELMORE, VT

Monthly Select Board Meeting

C. ACTIVE ITEMS:

1. **Discuss:** Health Related Policies

Notes: G. Schwartz met with Alison Link (Policy and Community Outreach for Healthy Lamoille Valley) on December 20, 2018. They discussed programs including community signage and Municipal Regulatory Tools. Alison will make a presentation at the next Planning Commission meeting on January 24, 2019. The Planning Commission will then present its recommendations to the Select Board.

D. CONTINUING ACTIVE ITEMS: (Update status by principle owner)

1. **UPDATE:** Road Commissioner's Report – Lacasse

Notes: The Road Commissioner stated that much of the past month has been spent plowing and sanding the town roads. Approximately 1/2 of the sand pile has been used so far this season.

2. **UPDATE:** Planning Commission – Schwartz

Notes: The Planning Commission met on December 18, 2018. Minutes of that meeting are available on the Elmore Website. The topics that were discussed were as follows;

- Zoning and Subdivision Amendments with Seth Jensen (LCPC)
- Town Plan priority Survey
- State Park Access

3. **UPDATE:** Development Review Board – DeVore

Notes: The Development Review Board did not meet since the last Select Board Meeting

4. **UPDATE:** Lake Association – Schwartz

Notes: Should receive notification shortly regarding the watershed assessment grant. The Lake Association will hold a pancake breakfast from 8:00 am – 10:00 am on the day of the polar plunge (February 9th) at the Fire House.

5. **UPDATE:** Elmore admittance to the State Park – Schwartz

Notes: The RiseVT Grant for community partners who support the initiative to embrace healthy lifestyles in the Amount of \$1,500.00 has been approved.

TOWN OF ELMORE, VT Monthly Select Board Meeting

6. **UPDATE:** Digital client services including email, server backups, document retention, disaster recovery, and equipment servicing. – Schwartz

a. Email Migration

Notes: Alario Tech made the switch over on January 8, 2019. Sharon's setup was completed on January 9, 2019. A training session will be setup for a future date.

b. Digital Records

Notes: Dan Alario was notified on January 2, 2019 on how to proceed with the digital records. Alario will setup the Adamero document management software license as cloud based. The cost will be \$35.00 per month. In addition, they will only move forward with digitization and retention processes for the following 4 categories of vital records at this time.

- Contracts: Any contract that the Town of Elmore signs (annual contracts like propane, oil, annual service contracts, etc.). Any bids that are received for a contract that is awarded should also be kept to demonstrate due diligence in the bidding and award process.
- Grants: All state grant background material including proof of work completed for grant approval or application supplementary documents that would not be part of the on-line application.
- Employee records: Applications, performance reviews (including disciplinary actions or warnings), salary reviews, benefits statements, etc.
- Licenses: This would include any vital records issued by the Town that are not captured or reflected at the State level. (Marriage, birth, etc. that are specific to the Town). Most of these are likely on file at the State level and don't require any additional retention at the Town level, but we wanted to include this in case there is something we hold only in the Town records.

7. **UPDATE:** Reclassifying roads, including Class 4 to a legal trail – DeVore

Notes: After Review by Bob Burley, it has been determined that there is no need to reclassify the roads at this time.

8. **UPDATE:** Budget Review – DeVore

Notes: The Select Board met on 1/7/19 to review the budget

TOWN OF ELMORE, VT
Monthly Select Board Meeting

E. COMPLETED/INACTIVE ITEMS: (Update status)

1. Review Action Item List

Notes: The action list was not reviewed at this meeting

E. NON AGENDA/OTHER ITEMS: (Time Available)

1. Routine Administrative, Operations items and payment approvals.

F. EXECUTIVE OR DELIBERATIVE SESSION AS NEEDED

What will be the new vehicle's primary function?

- Fire Suppression / Motor vehicle accidents / Hauling water (Tanker) / Water supply

What physical characteristics are critical for the new vehicle?

- Shorter wheel base for better maneuverability for tight/steep driveways (Worcester Ridge).
- Rear suction for the ability to put portable pond in driveway or keep a road open to one lane.

What is the vehicle's projected activity level?

- In the last 5 years there has been 72 calls for service in the Town of Elmore. Out of those 72 the project new E2 would have responded to at least 38 of those calls or 52% (structure fires, car accidents).

What are the apparatus operator's qualification needs?

- Current E2 is a standard transmission. This would make it easier to training and be safer for operation as standard transmission is not common anymore.

Purchase of a used truck?

- Only get 10-15 years of service out of it
- Most likely limited warranty
- Unknown what kind of problems you will be getting into
- Hard to find a used Commercial chassis that would fit our needs. Most used trucks are cab over trucks
- Are they built with panel heaters and capable or working in Vermont Conditions

New Truck Purchase:

- Would be built to our needs
- We currently have an aging Rescue truck that often has to go out for service, this puts a lot of our tools out of service with it. We would have more cabinet space which we would be able to take some equipment off R1 and prolong the life of that truck.
- E2 would be equipped with the Jaws of life and would respond to car accidents having the capabilities of vehicle extrication and fire protection with one truck.
- When E1 goes in for service, we would have no capabilities of fire suppression. That is NOT safe for our community and puts lives at risk.
- Life of a new fire truck could be 25-30 years.

-Truck will be equipment with the newest safety for occupants (airbags, seat belts, shuts off going to fast into corners). Used truck may not have the most so of these features.

Why can't EFD relay on Mutual Aid?

- We currently do relay on mutual aid from Wolcott FD (both dept).
- Wolcott FD has all time low membership and has a hard time getting enough people to handle calls in Wolcott alone.
- Morrisville FD during the day time lately has only had 3 people at most.
- Worcester FD we have called in the past during the day and no one ever responded.
- Those 3 towns are the closest for Mutual Aid. At this time volunteers are hard to find, more so during the day.
- There would most likely be a very long response time to get the needed equipment to the scene if we relied on mutual aid which is a risk to the community of Elmore.
- Elmore has been very lucky that we have been able to average 5-8 people during the day time response.
- Having One pumper on scene and not knowing when the next one or tanker would arrived would limit our ability to preserve life and property for the residents of Elmore and possibly put us in danger.

Elmore Town Highway:

- Elmore Highway has been purchasing new equipment, dump trucks etc.
- I think they do it for the same reason we are wanting to purchase a new fire truck over something used.

What EFD has done for equipment in the past?

- We have secured multiple grants, most recently for new airpacks. We saved the Town over \$68,000 with this grant alone. Other grants has got us a trailer, atv, airbottle fill station, generators, lights, wildland gear, pagers the list goes on.
- We have fund raised money for purchase of a Rescue truck and special equipment.
- We try not to have an impact on the tax payers and rarely asked for a lot unless we see that there is a life safety need for it. In this case it is for the safety of the people who are volunteering their time to help people in need and for those who are in need.

Towns nearby replacement schedule:

-Morrisville FD is replacing trucks every 20 years
MFD just bought a mini pumper for \$227,000

-Wolcott FD has been replacing every 15 years

-North Hyde Park FD is purchasing a new Engine for just over \$300,000

1979 EFD 45 Engine 2 - Inspection 2018

Elmore Fire Department

In summary, the 2018 inspection resulted in an overall concern for life safety for not only the vehicle operators, but also for other vehicles, pedestrians, and emergency responders at a scene.

- The vehicle will not pass inspection without significant repair (approximately \$12K).
- The brake system is hydraulic, not air. The brake system operates at either 2200 psi or 4400 psi depending on brake pedal pressure. The brake lines are showing rust. Potentially failing brakes is of high concern when responding to incidents or during training especially when adrenaline levels are high (hitting the brakes harder).
- The brake booster assembly is no longer available for purchase (complex rebuild is the only option).
- The emergency brake barely keeps the vehicle stopped when on a hill thus wheel chocks are critical. When operated this brake wraps around and holds the driveshaft so any damage to the shaft or U-joints will result in emergency brake failure.
- The driver step has heavy rust affecting structural stability and will need rebuilding to pass inspection.
- The storage compartments and other areas of the vehicle body are rusting and will continue to rust even while kept indoors as rust continues to grow according to the inspection mechanic.

EFD Stats	2018	2017	2016	2015	2014
Fire - Structure	3	2	0	1	4
Fire - Car	1	0	0	1	0
Fire - Vegetation	2	0	2	0	0
Fire - Other	3	1	0	0	1
CO	4	3	1	3	0
Fire Alarm	7	1	0	1	2
Medical	1	1	1	1	3
Car Accident	5	3	2	2	5
Other	0	0	2	1	3
Total	26	11	8	10	17

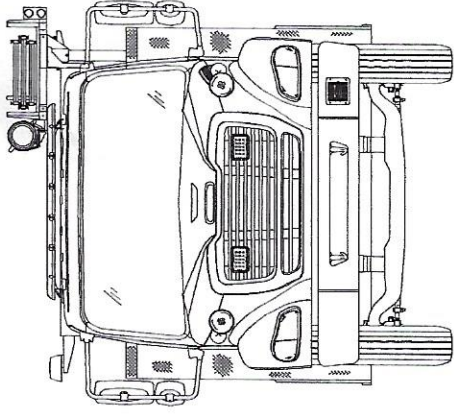

FRONT VIEW

COMPT.	CLEAR DOOR OPENING (W x H)	COMPARTMENT INTERIOR (W x H x L/D/D)
L1	41-1/4" W x 65" H	46" W x 31-1/4" H x 27" D L / 46" W x 34-1/4" H x 14" D U
L2	30-1/2" W x 65" H	38" W x 31-1/4" H x 27" D L / 38" W x 34-1/4" H x 14" D U
L3	36-1/2" W x 23-3/4" H	45" W x 34-1/4" H x 14" D
L4	25-1/2" W x 65" H	30" W x 31-1/4" H x 27" D L / 30" W x 34-1/4" H x 14" D U
R1	30-1/2" W x 59-1/2" H	38" W x 31-1/4" H x 27" D L / 38" W x 38-3/4" H x 14" D U
R2	41-1/4" W x 27" H	46" W x 34-1/4" H x 27" D
R3	25-1/2" W x 27" H	30" W x 34-1/4" H x 27" D

OFFICER SIDE VIEW

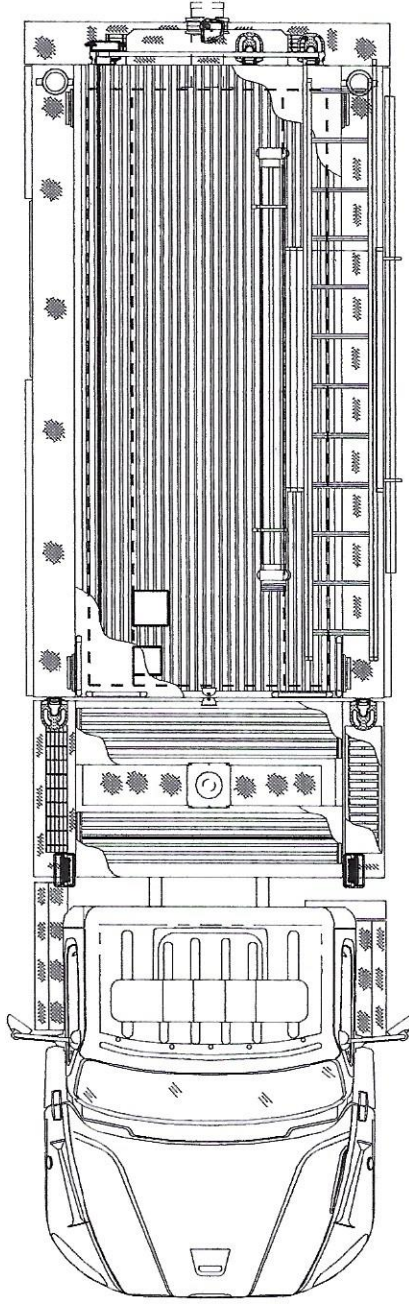
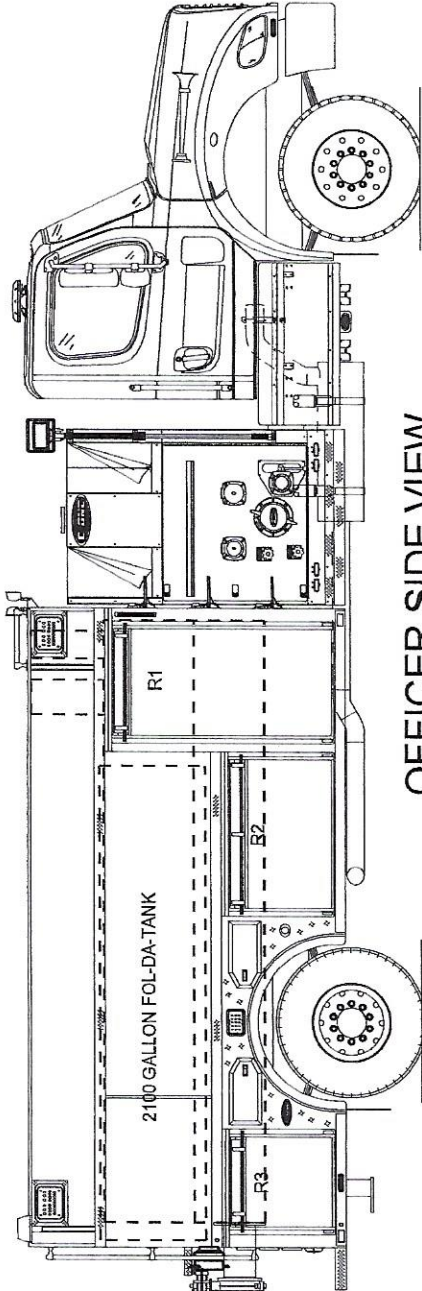

TOP VIEW

CROSSLAY #1 = 200" OF 1-3/4" HOSE CROSSLAY #2 = 200" OF 1-3/4" HOSE DEADLAY #3 = 8" DUMP TUBE STORAGE

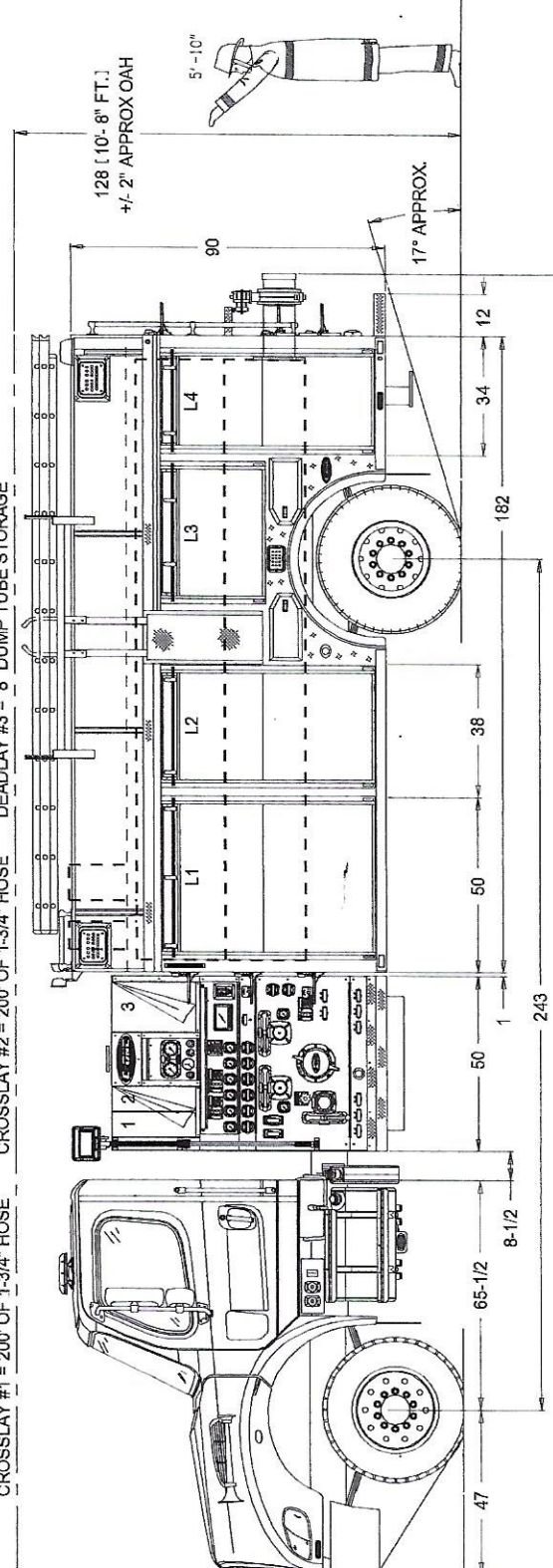

REAR VIEW

HOSE BED LAYOUT:
 BED 1 = 1500' OF 4" HOSE
 BED 2 = 300' OF 2-1/2" HOSE

E D C B

2

3

4

5

6

7

S
NTS
IE
NIL

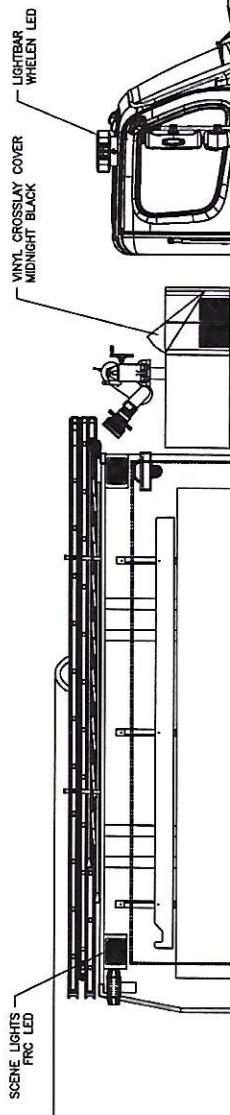
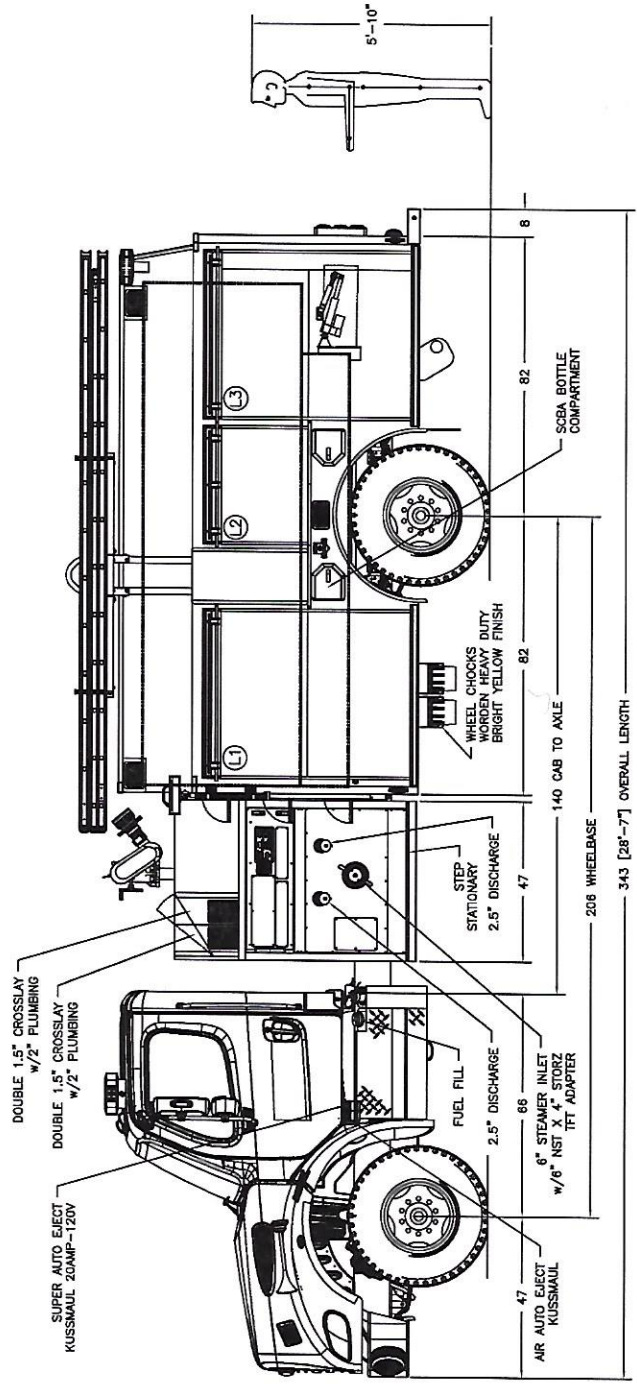
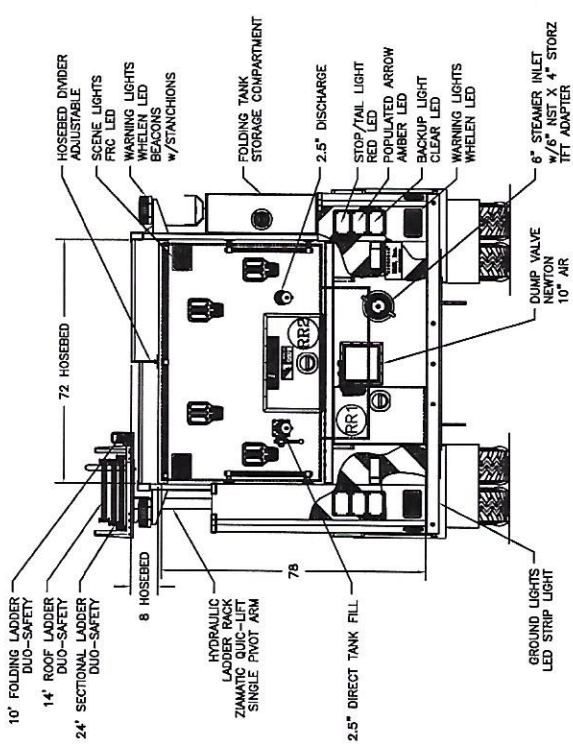
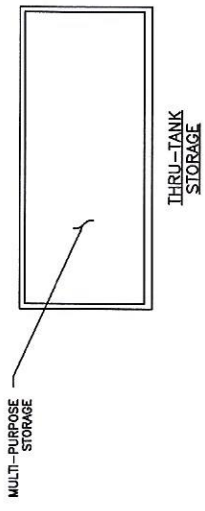
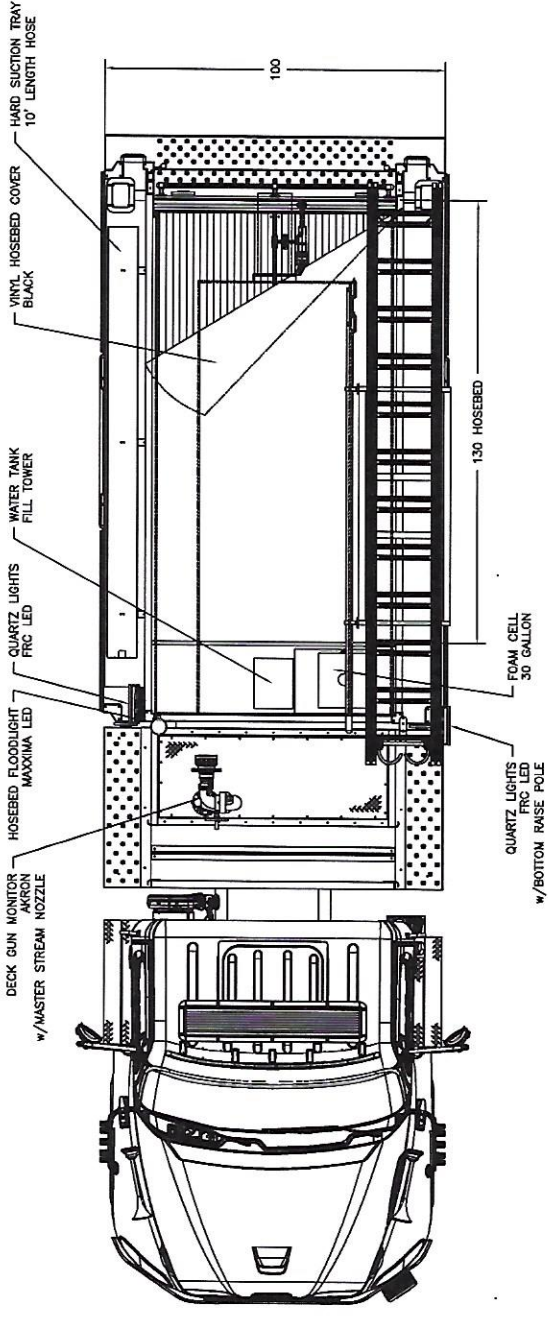

NG	COMPT.
DOOR	EIGHT
34.3"	VOLUME
2.3	FT3